



# A Small Winery Rinsing Device for Grape-Harvesting Containers

Fred L. Shuman, Jr.



**MAFES**

MISSISSIPPI AGRICULTURAL & FORESTRY EXPERIMENT STATION  
R. RODNEY FOIL, DIRECTOR MISSISSIPPI, STATE, MS 39762

Mississippi State University

James D. McComas, President

Louis N. Wise, Vice President



# A Small Winery Rinsing Device for Grape-Harvesting Containers

**Fred L. Shuman, Jr.**, agricultural engineer, MAFES/Mississippi State University Department of Agricultural and Biological Engineering and processing engineer, A. B. McKay Food and Enology Laboratory

# A Small Winery Rinsing Device for Grape-Harvesting Containers

Plastic lugs (containers) are used in the harvesting of grapes, peaches and other fruit in the various horticultural research programs in the Mississippi Agricultural and Forestry Experiment Station. These containers must be cleaned after each use to minimize contamination. Removal of leaves and trash is difficult because fruit and plant juices on the interior surfaces of the containers become sticky and essentially "glue" the material to the inside. It is desirable to remove both the debris and the plant and fruit juices.

Several cleaning methods were tried in the development of a suitable process, and most required considerable hand labor and time. This bulletin describes a simple washer developed to reduce the time and labor normally associated with cleaning these containers.<sup>1</sup> The device was constructed for cleaning containers used in hand harvesting of grapes for processing in the A. B. McKay Food and Enology Laboratory.

## Equipment

A typical lug is the No. 1411 Harvest Tainer<sup>®</sup> manufactured by NOSCO Plastics, Inc., 300 Garden City Plaza, Garden City, New York. This perforated container is about 23 inches (58.4 cm) long by 15 inches (37.8 cm) wide by 7 inches (17.8 cm) deep. The device developed for rinsing these containers is shown in Figures 1 and 5.

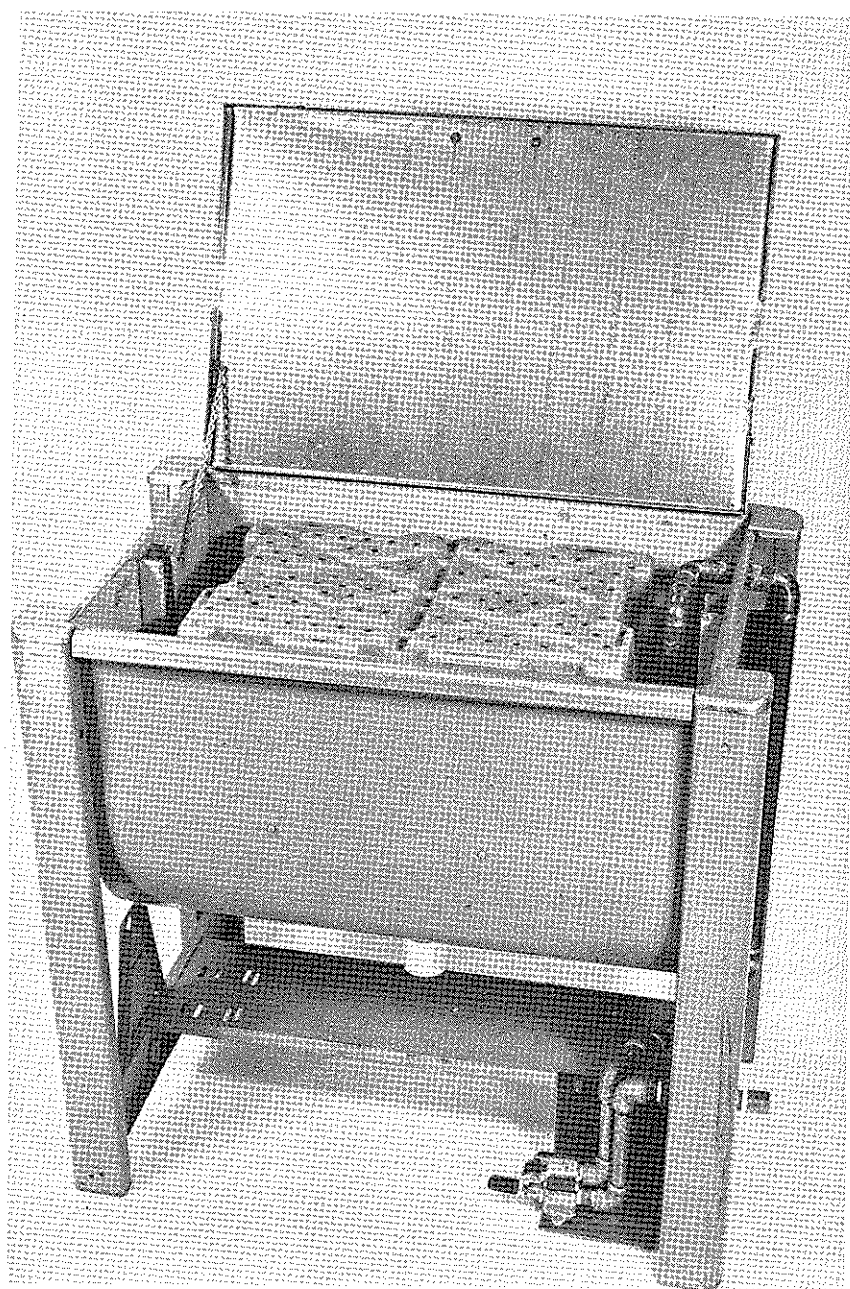

Figure 1. Rinsing device for harvesting containers (with top open).

<sup>1</sup>Appreciation is acknowledged to Mr. Anthony Blair, Mr. Cloyd Robinson and Mrs. Neva Wolfe (members of the technical staff of the Agricultural and Biological Engineering Department) for their assistance in the construction and testing of this device and to Mr. Hugh Hudson, student photographer, for the photographic work.

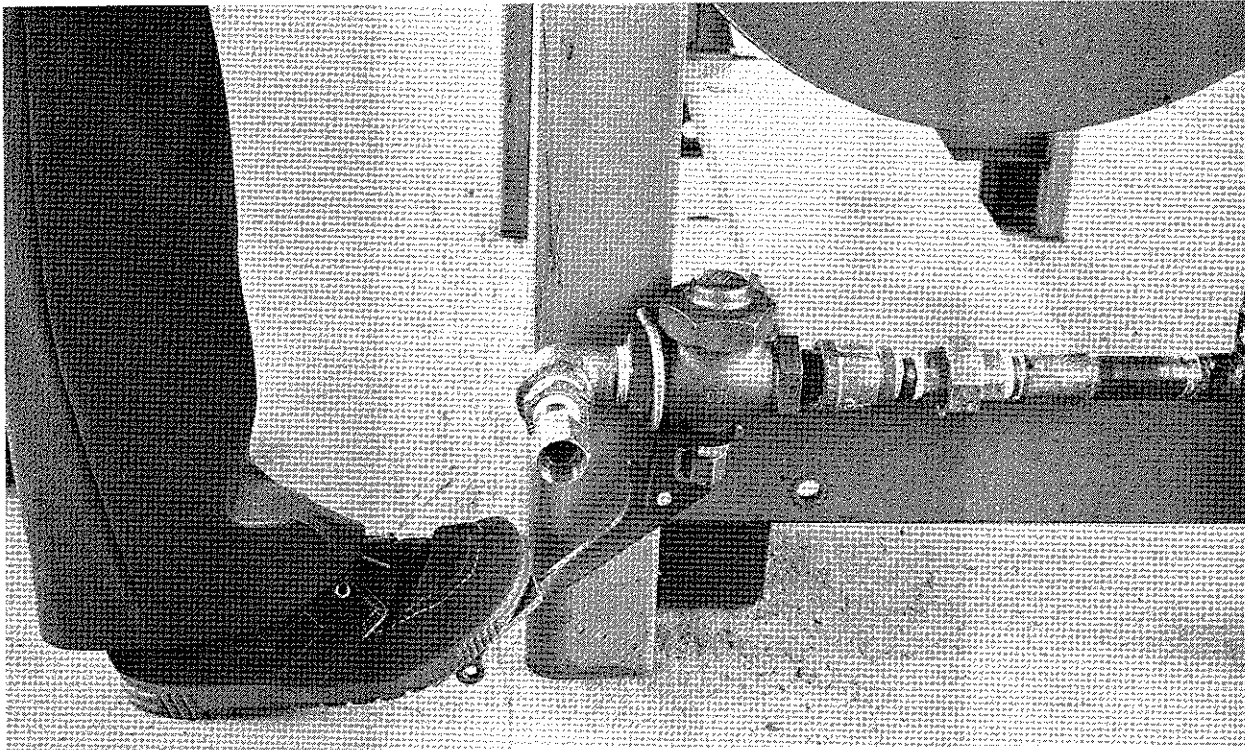

Figure 2. Modified foot-operated valve.

The basic tank and supporting framework can be fabricated from sheet metal and structural steel; however, the tank used in this application was an available photographic print-washing tank equipped with bottom and overflow drains. The components added were a foot-operated valve (Figures 1 and 2---note two possible configurations), a stainless steel hinged top (Figure 1), eight nozzles (Figures 3 and 4) and the required plumbing.

Factors governing the effectiveness of this device were the orientation of the nozzles and the pressure and quantity flow of water. The nozzles used in this application were Tee Jet® TG-10 nozzles manufactured by the Spraying Systems Co., North Avenue and Schmale Road, Wheaton, IL 60187 (Distributed by W. G. Smart Co., Inc., P. O. Drawer 1777, Covington, LA 70433). The nozzles were oriented initially at 90

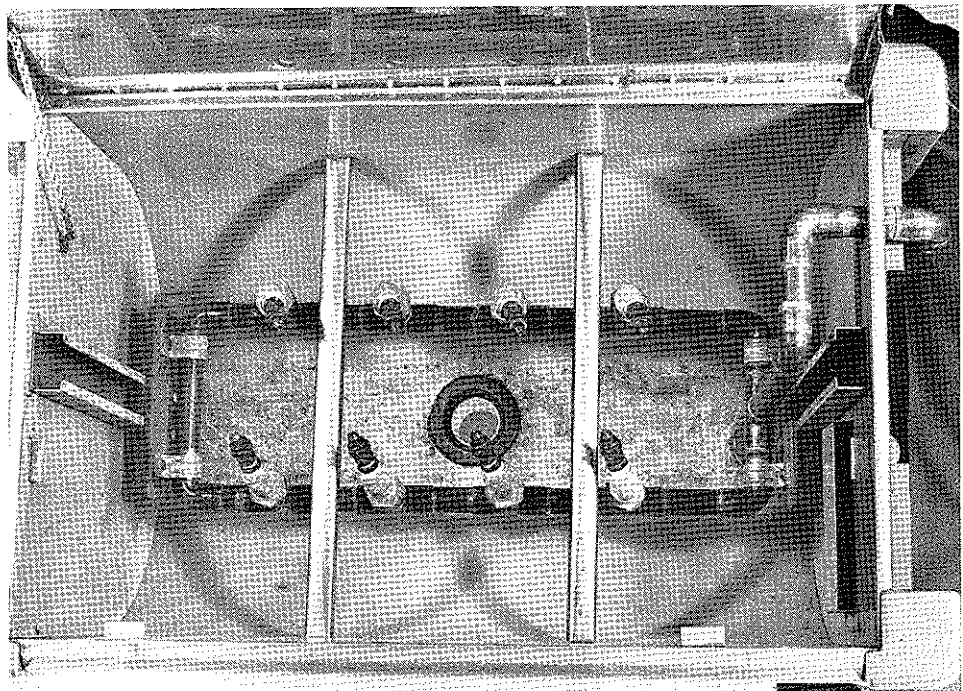

Figure 3. Nozzle location and orientation.



degrees (perpendicular) to the bottom inside surface of the inverted harvesting containers. The water jets from the nozzles removed some of the unwanted materials but also tended to force some of the material against the surface and hold it there. Various angles of orientation were tested in an attempt to inject high velocity water between the debris and the bottom inside surface of the container. The angles that produced the best results with the combination of nozzles, piping, valve and water

pressure used in these tests are the ones shown in Figures 3 and 5. Water flow in the early designs was restricted by the size of the passages (1/2-inch National Pipe Thread) in the original foot-operated valve (Figure 1). A larger valve (Spraying Systems Part No. 3558-1, manufactured by Lunkenheimer Flow Control, Cincinnati, OH 45214 and distributed by W. G. Smart, Inc.) with one-inch NPT inlet and outlet ports was installed to provide the appropriate flow rate and to minimize pressure

loss throughout the system (Figure 2). The flow rate was about 18 gallons per minute during the time that the foot pedal was depressed. The inlet pressure from the water line was about 60 pounds per square inch in the tests conducted with the washer.

Standard one-inch copper tubing and fittings and galvanized pipe and fittings were used throughout after installation of the larger valve.

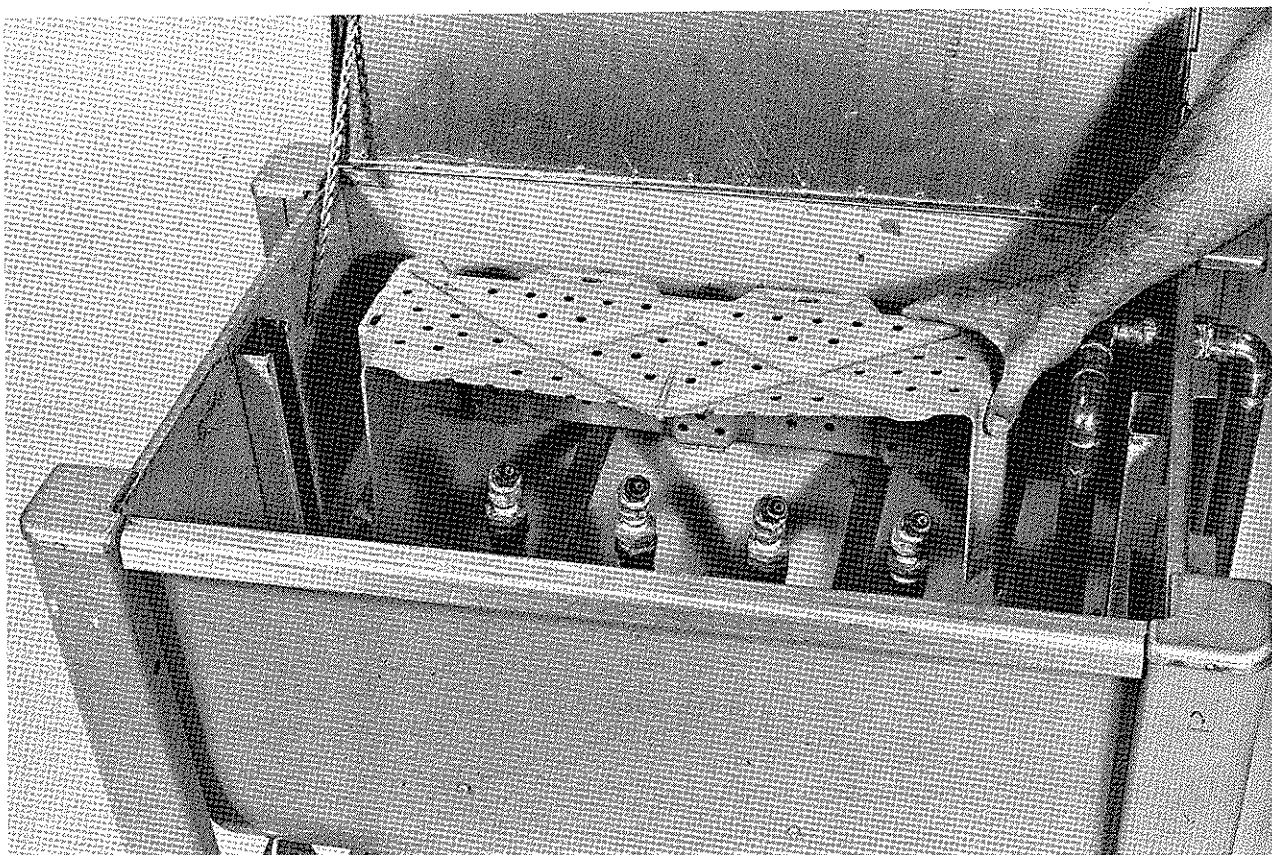
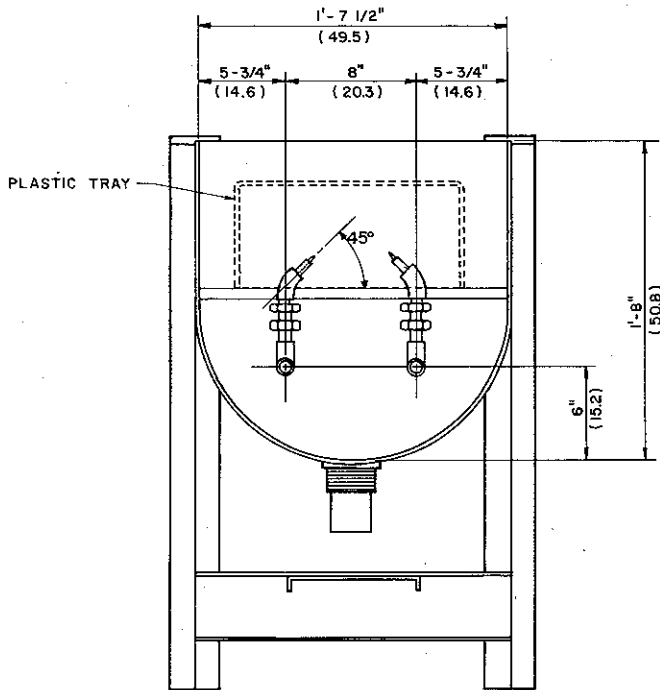
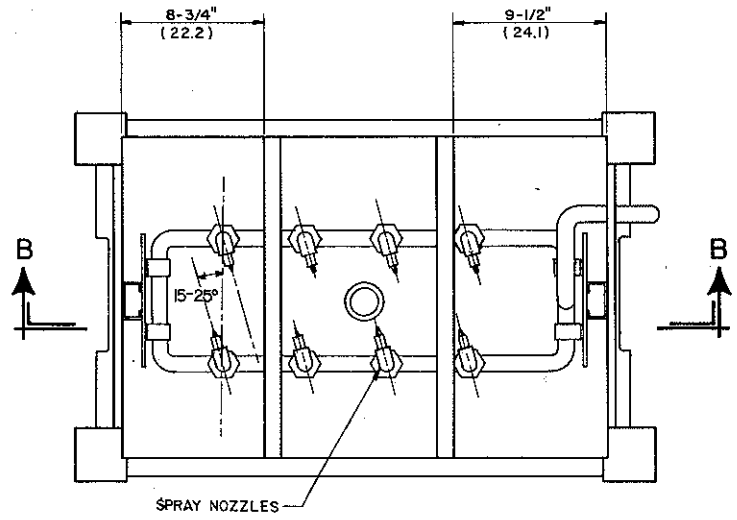

Figure 4. Relationship between nozzles and harvesting container (cutaway).



SECTION A-A



TOP VIEW

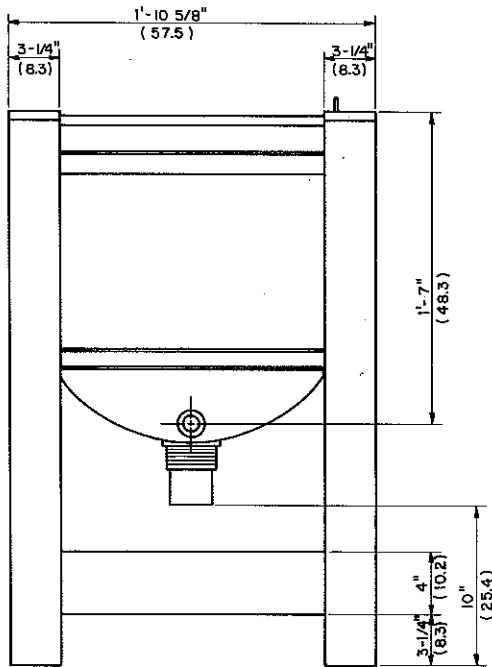

LEFT SIDE VIEW

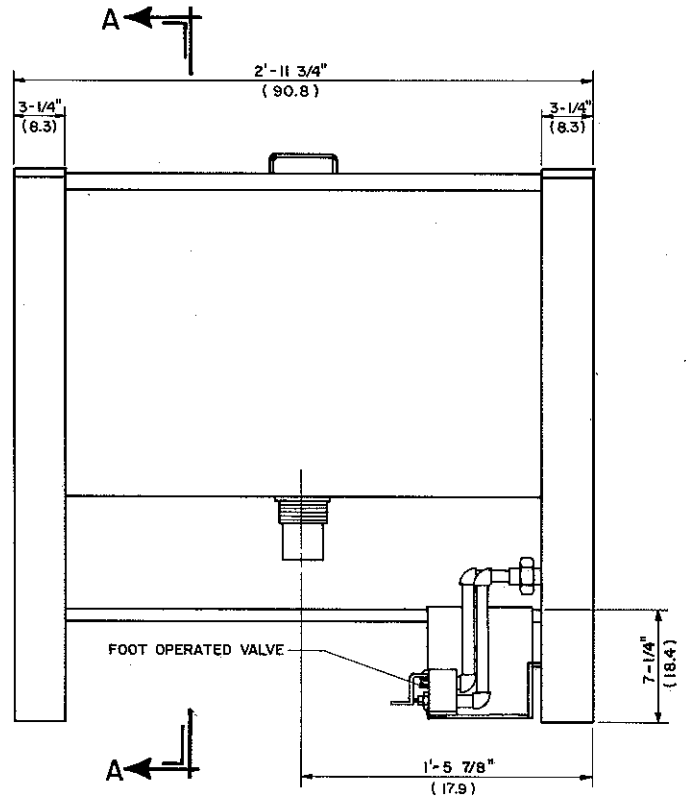

FRONT VIEW

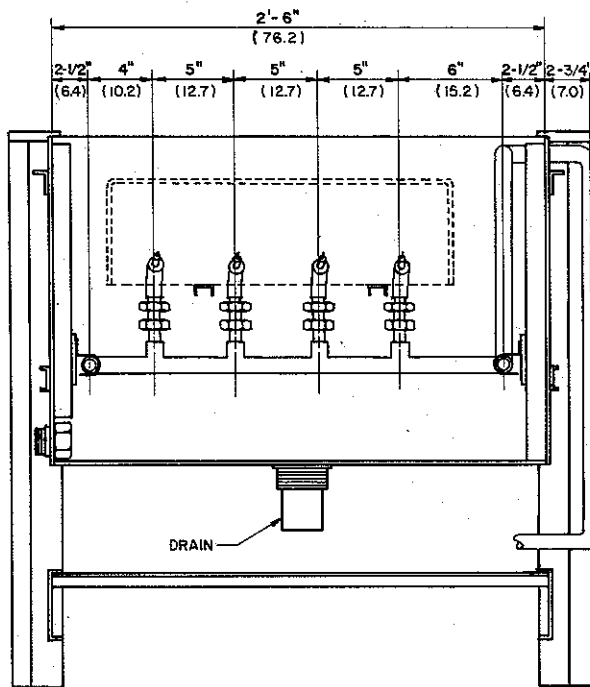

**SECTION B-B**

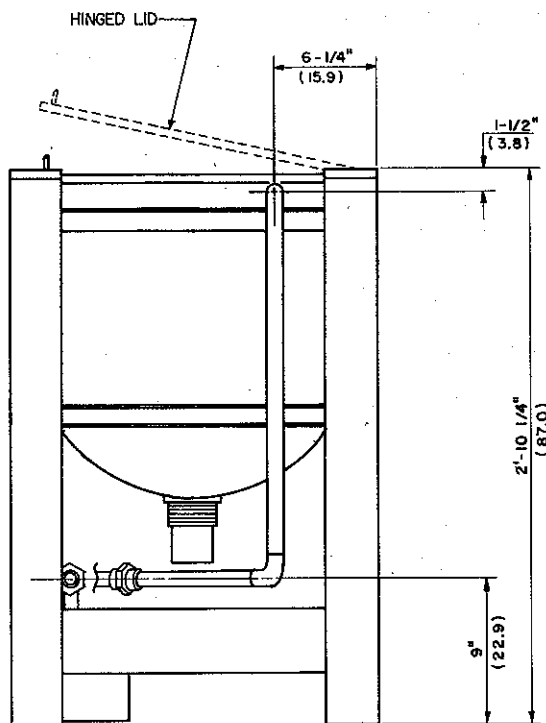

**RIGHT SIDE VIEW**

**Operating Procedure**

The procedure for using the washer is as follows:

1. The container was passed to the person operating the washer as the grapes were emptied from each plastic container. The timing was coordinated with the grape crushing and destemming operation to result in a relatively continuous process.
2. The container was placed upside down in the open washer and was rested on the support rails as shown in Figure 4.
3. The lid of the washer was closed.
4. The operator stepped on the control lever of the foot-operated valve for a few seconds. The length of time required varied with the amount and type of debris to be removed and was varied simply on the basis of operator experience. It was determined that intermittent operation of the foot pedal produced a pulsating jet from the nozzles, which was more effective than continuous flow.
5. The cover was opened.
6. The clean container was removed and was stacked in an inverted position to drain dry.

**Figure 5. Construction drawings for harvesting container rinsing device.**

NOTE: ALL DIMENSIONS IN ( ) ARE METRIC, IN CENTIMETERS.

## Conclusions and Recommendations

The present design of the washer provides adequate rinsing of debris from the containers, and the nozzle orientation used provides satisfactory results for the operating conditions encountered. The device reduced the amount of time and labor involved in cleaning the containers.

One possible improvement would be the addition of a mechanism to produce a pulsating jet or a rotating spray. It is anticipated that such a modification will be made to the existing unit.

The estimated cost of materials for construction of the washer at current prices (using an angle iron frame and galvanized sheet metal tub, with all other components the same as used in this unit) would be about \$160, excluding the cost of the foot-operated valve for which alternatives are available.

The cost of the Lunkenheimer valve used in this application was \$138. A similar quick-opening, lever-arm, globe valve (with composition seat) is available for \$85 from McMaster-Carr Supply Com-

pany, P.O. Box 4355, Chicago, IL 60680. The overall cost of the unit could be reduced considerably by using a simple, manually operated ball valve or butterfly valve (located at a convenient operating point) that costs about \$15 (McMaster-Carr). The same type of valve could be modified for operation with a foot pedal and return spring. Total cost of the unit will depend to an extent on the ingenuity and capabilities of the fabricator.



*Mention of a trademark or proprietary product does not constitute a guarantee or warranty of the product by the Mississippi Agricultural and Forestry Experiment Station and does not imply its approval to the exclusion of other products that also may be suitable.*

Mississippi State University does not discriminate on the basis of race, color, religion, national origin, sex, age, or handicap.

In conformity with Title IX of the Education Amendments of 1972 and Section 504 of the Rehabilitation Act of 1973, Dr. T. K. Martin, Vice President, 610 Allen Hall, P. O. Drawer J, Mississippi State, Mississippi 39762, office telephone number 325-3221, has been designated as the responsible employee to coordinate efforts to carry out responsibilities and make investigation of complaints relating to discrimination.